

CLASSIC 290 FT

(Folding Transom)

SPECIFICATIONS

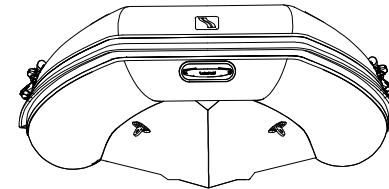
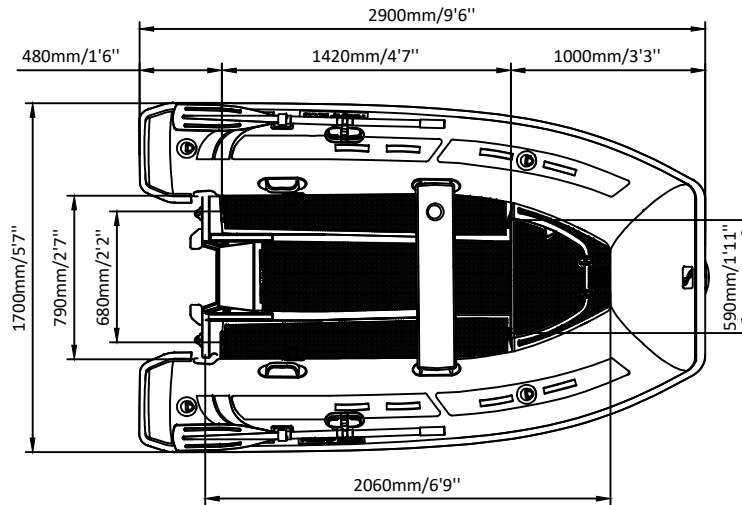
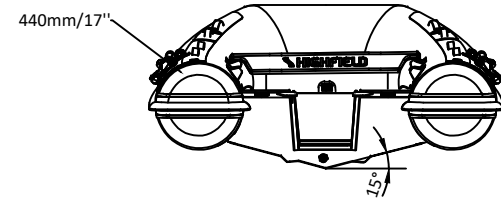
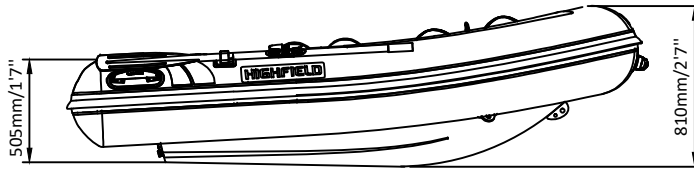

SPECIFICATIONS AND MAXIMUM CAPACITIES (Subject to change without notice. Tolerances: Dimensions $\pm 2.5\%$ Weight $\pm 5\%$) Note: red means lifting eyes.

MODEL	ISO 6185 PART	ISO 6185	Lifting eyes			Person		Outboard Engine				Molded seat		Oars		/		Fuel tank Capacity		Wet Weight (Approximate) 20HP (14.92KW)		AIR CHAMBERS	Pressure				
			KG	LB	#	KG	LB	Shaft	Max power		Max weight		KG	LB	KG	LB	/	/	L	GAL	KG		LB	PSI	BAR		
									KW	HP	KG	LB															
CL290FT	2	C	480	1058	4	300	661	S	14.92	20	104.5	230	59	130	3	6.6	1.5	3.3	/	/	/	/	168	370	3	3.63	0.25

Weight: boat only.

2021V4

CLASSIC 290

(Short Shaft)

SPECIFICATIONS

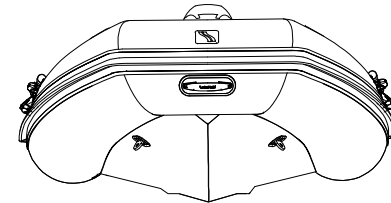
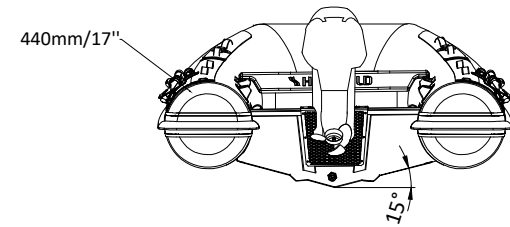
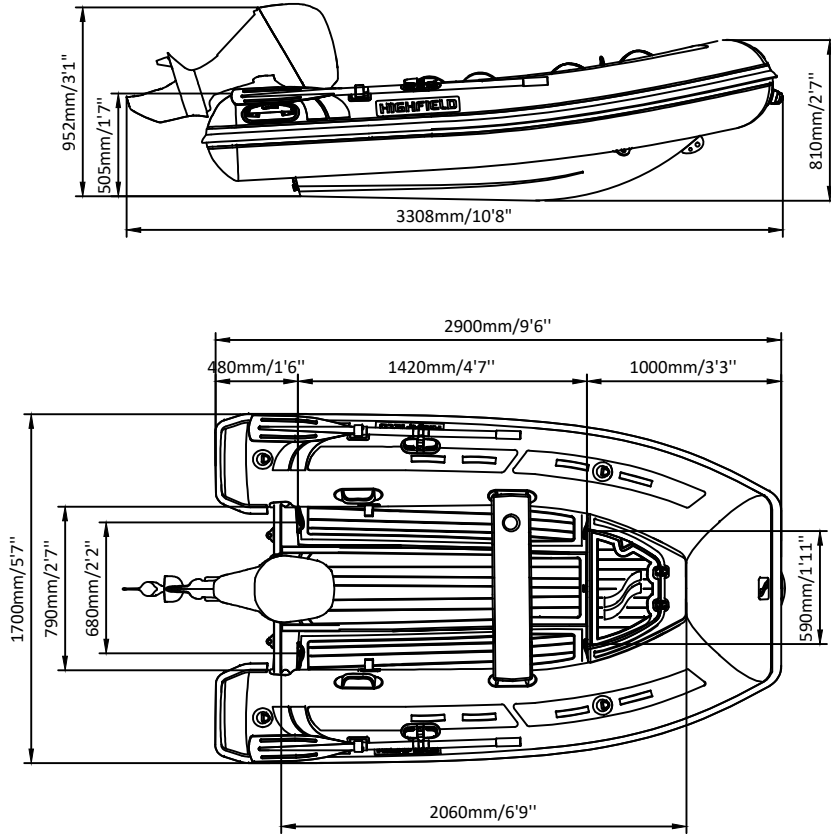

SPECIFICATIONS AND MAXIMUM CAPACITIES (Subject to change without notice. Tolerances: Dimensions ±2.5% Weight ±5%) Note: red means lifting eyes.

MODEL	ISO 6185 PART	ISO 6185	Passengers			Outboard Engine				Molded seat		Oars		/		Fuel tank Capacity		Wet Weight (Approximate) 20HP (14.92KW)		AIR CHAMBERS	Pressure						
			KG	LB	#	KG	LB	Shaft	Max power	Max weight	KG	LB	KG	LB	/	/	L	GAL	KG		LB	PSI	BAR				
								KW	HP	KG	LB																
CL290	2	C	480	1058	4	300	661	S	14.92	20	104.5	230	59	130	3	6.6	1.5	3.3	/	/	/	/	168	370	3	3.63	0.25

Weight: boat only.

2021V6

CLASSIC 290 FT

(Folding Transom)

SPECIFICATIONS

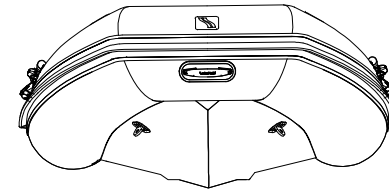
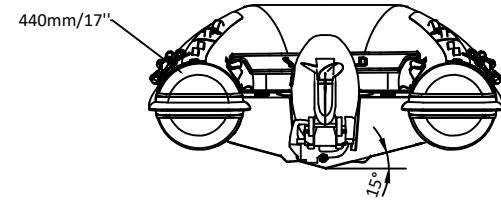
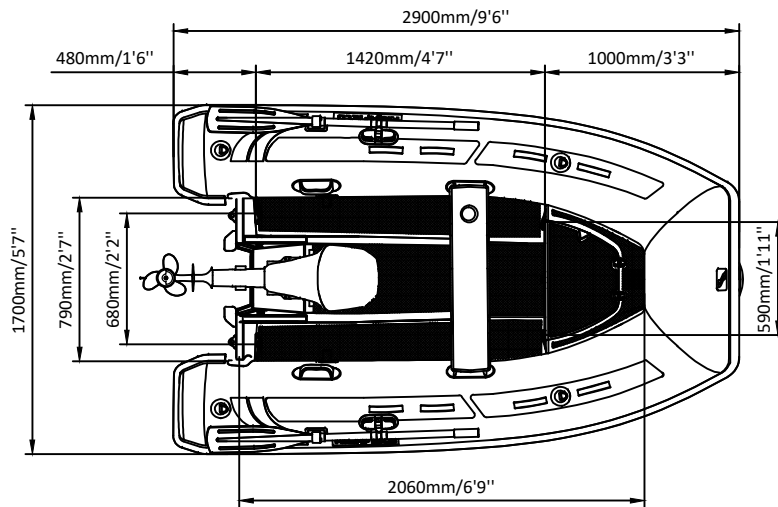
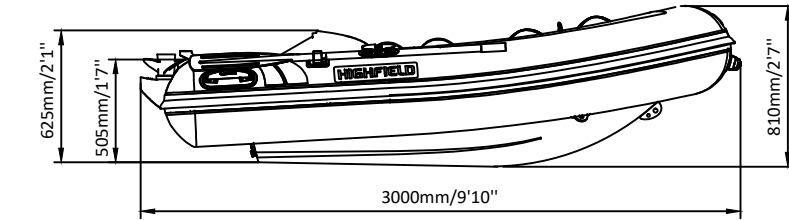

SPECIFICATIONS AND MAXIMUM CAPACITIES (Subject to change without notice. Tolerances: Dimensions ±2.5% Weight ±5%) Note: red means lifting eyes.

MODEL	ISO 6185 PART	ISO 6185			#			Outboard Engine	Molded seat				Oars		/		Fuel tank Capacity		Wet Weight (Approximate) 20HP (14.92KW)		AIR CHAMBERS 						
			KG	LB		KG	LB		Shaft	Max power		Max weight		KG	LB	KG	LB	/	/	L		GAL	KG	LB	PSI	BAR	
										KW	HP	KG	LB														
CL290FT	2	C	480	1058	4	300	661	S	14.92	20	104.5	230	59	130	3	6.6	1.5	3.3	/	/	/	/	168	370	3	3.63	0.25

Weight: boat only.

2021V5

CLASSIC 290

(Short Shaft)

SPECIFICATIONS

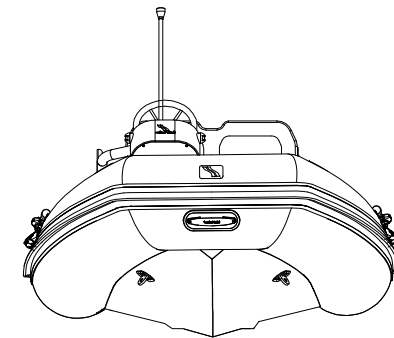
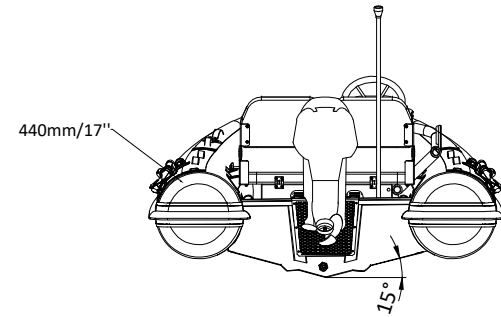
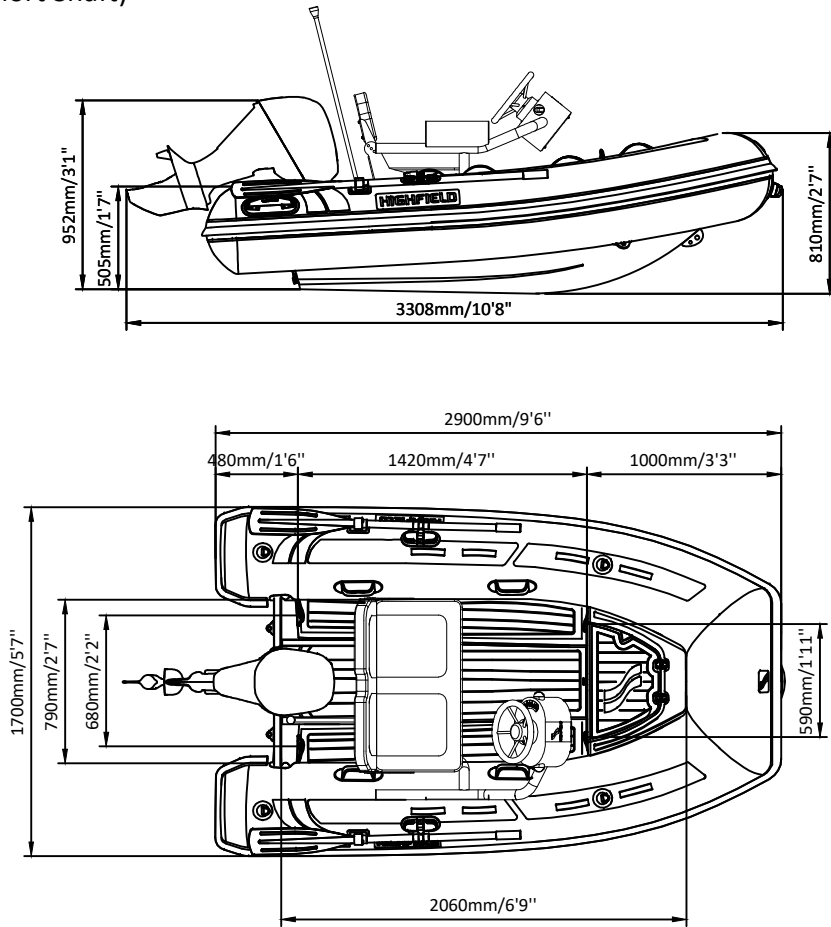

SPECIFICATIONS AND MAXIMUM CAPACITIES (Subject to change without notice. Tolerances: Dimensions ±2.5% Weight ±5%) Note: red means lifting eyes.

MODEL	ISO 6185 PART	ISO 6185					Outboard Engine						FCT		Molded seat		Oars		Fuel tank Capacity		Wet Weight (Approximate) 20HP (14.92KW)		AIR CHAMBERS				
			KG	LB	#	KG	LB	Shaft	Max power		Max weight		KG	LB	KG	LB	KG	LB	L	GAL	KG	LB		PSI	BAR		
									KW	HP	KG	LB															
CL290	2	C	480	1058	4	300	661	S	14.92	20	104.5	230	59	130	36	79	3	6.6	1.5	3.3	/	/	204	450	3	3.63	0.25

Weight: boat only.

2021V6